



**Advantix shower channel  
with Advantix grate Visign ER10**  
- for bonded sealing (tiled shower) or sealing lane

**Equipment**

sand-coated sealing flange, polished grate, adjusting feet set, removable odour trap, cleaning possibility for connection line, rotatable drain DN40, adapter to DN50, sieve insert

**quality controlled in accordance with DIN EN 1253  
Model 4983.10**

**Article 753 160**

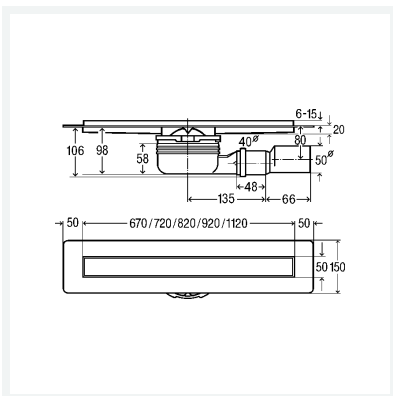

## Properties

Load class	LC	K=300 kg
Water seal level	WSL	50 mm
Drainage capacity 10 mm (in accordance with DIN EN 1253)	DC 10	0.5 l/s
Drainage capacity 20 mm (in accordance with DIN EN 1253)	DC 20	0.55 l/s
Length	L	800
Weight	9.962 lb	
Volume	53286.316 cm <sup>3</sup>	
Material	Material	stainless steel 1.4301